

CS900

This counter-model high volume slush freezer features a small footprint. The CS900's consistency control is designed to dispense the finest frozen product available. Great for restaurants, QSRs, beach resorts, bars and restaurants.



Optional

- **Flavor Rack**
- **Top Air Discharge Chute** the top air discharge chute on air cooled models allows units to be set side by side and air flow to be diverted up.
- **Cabinet** an optional commercial grade stainless steel cabinet is available includes heavy duty casters, a sturdy latch and gives you 6 cubic feet of storage.

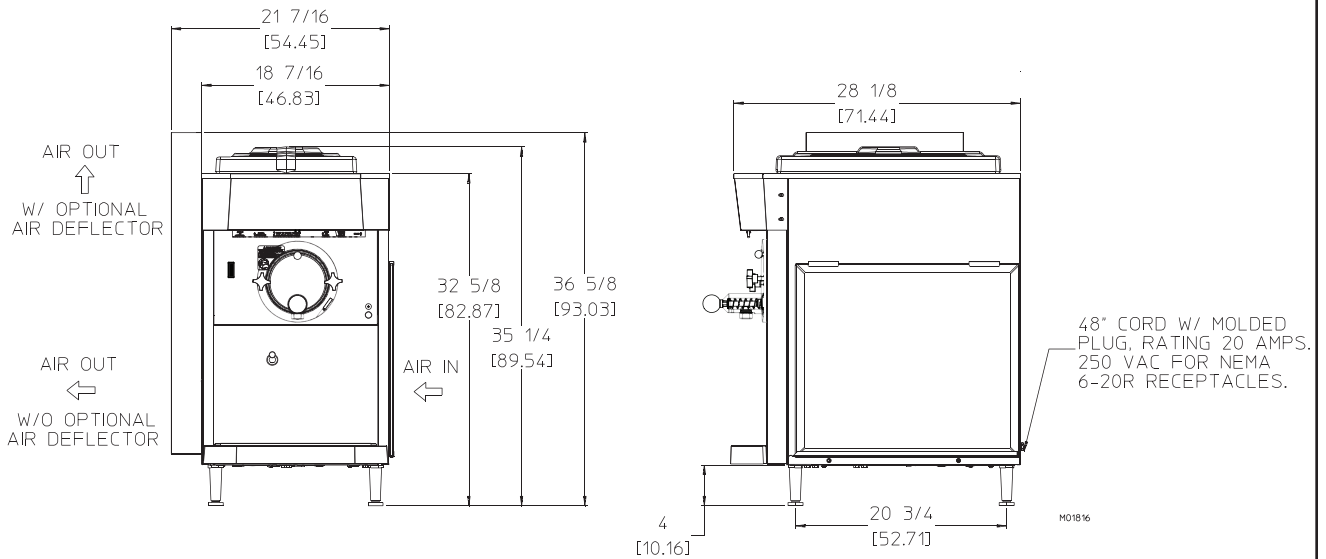

MODEL CS900 SPECIFICATIONS

Due to continual product improvements *all specifications are subject to change without notice.*

Weights	lbs.	kgs.	
Net	294	133.36	
Crated	390	176	
	cu.ft.	cu.m.	
Volume	39.47	1.12	
Dimensions	in.	cm	
Width	18-7/16	46.83	
Depth	28-1/8	71.44	
Height	35-1/4	89.54	
Electrical	Maximum Fuse Size	NEMA Plug Type	Poles (P) Wires (W)
208-230/60/1 Air	12.5	6-20P	2P, 2W
	Total Amps	kW	Poles (P) Wires (W)
220-240/50/1 Air	12	2.4	2P, 2W

Electrical characteristics other than above available on request from factory or local distributor. Check nameplate for exact electrical data.

Specs are subject to change pending UL certification.

Bidding Spec

Electrical: Volt _____ Hz _____ Ph _____

Cooling: _____ Neutral _____ Yes _____ No

Options: _____

Electrical

One dedicated electrical connection is required. Connects to a standard NEMA 6-20R receptacle. See electrical chart for the proper requirement. Consult your local electrical codes for receptacle specifications.

Beater Motor

One, 1/2 hp.

Refrigeration Systems

One, 8,000 Btuh. R404a.
Btuh may vary depending on compressor used.

Air Cooled

3" (7.6cm) air space required on both sides and the rear panel for proper air circulation.

Mix Hopper Capacity: one - 20 quarts (18.8 liters)

Freezing Cylinder Capacity: one - 7.6 quarts (7.1 liters)



Electro Freeze div. of H.C. Duke & Son, LLC

2116-8th Avenue, East Moline, Illinois 61244 USA

Phone (309) 755-4553 • (800) 755-4545

FAX (309) 755-9858

E-mail: sales@electrofreeze.com • www.electrofreeze.com

Authorized Distributor